

$E_{AS}$  450 mJ, 345 V internally clamped IGBT

## Features

- Low threshold voltage
- Low on-voltage drop
- High current capability
- High voltage clamping feature
- Gate and gate-emitter integrated resistor

## Application

- Automotive ignition

## Description

This application specific IGBT utilizes the most advanced PowerMESH™ technology. The built-in Zener diodes between gate-collector and gate-emitter provide overvoltage protection capabilities. The device also exhibits low on-state voltage drop and low threshold drive for use in automotive ignition system.

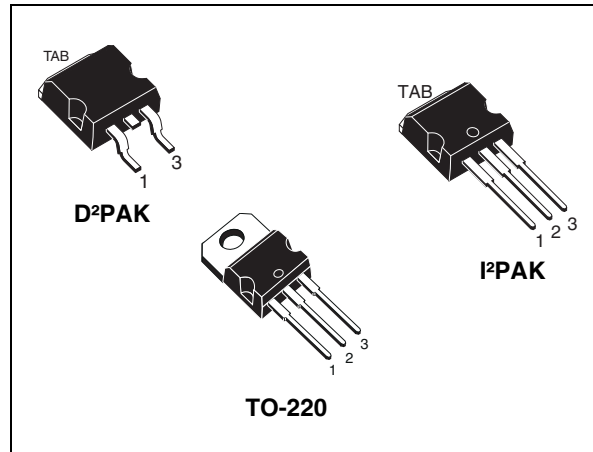

**Figure 1. Internal schematic diagram**

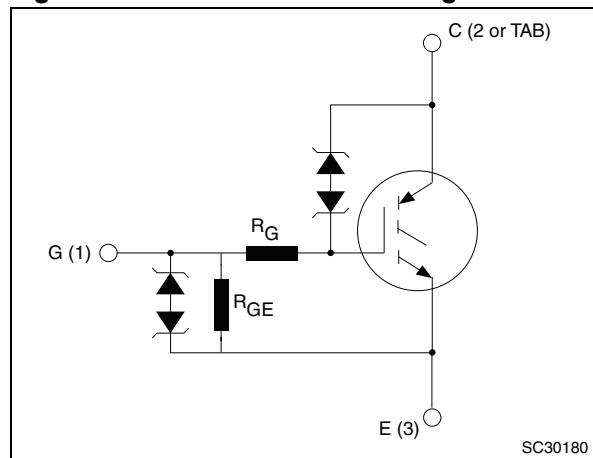

**Table 1. Device summary**

Order codes	Marking	Package	Packaging
STGB35N35LZ-1	GB35N35LZ	I <sup>2</sup> PAK	Tube
STGB35N35LZT4	GB35N35LZ	D <sup>2</sup> PAK	Tape and reel
STGP35N35LZ	GP35N35LZ	TO-220	Tube

# Contents

<b>1</b>	<b>Electrical ratings</b> .....	<b>3</b>
<b>2</b>	<b>Electrical characteristics</b> .....	<b>4</b>
2.1	Electrical characteristics (curves) .....	6
<b>3</b>	<b>Test circuit</b> .....	<b>9</b>
<b>4</b>	<b>Package mechanical data</b> .....	<b>10</b>
<b>5</b>	<b>Packaging mechanical data</b> .....	<b>14</b>
<b>6</b>	<b>Revision history</b> .....	<b>15</b>

# 1 Electrical ratings

**Table 2. Absolute maximum ratings**

Symbol	Parameter	Value	Unit
$V_{CES}$	Collector-emitter voltage ( $V_{GE} = 0$ )	$V_{CES}$ (clamped)	V
$V_{ECS}$	Emitter collector voltage ( $V_{GE} = 0$ )	20	V
$I_C^{(1)}$	Continuous collector current at $T_C = 25\text{ °C}$	40	A
$I_C^{(1)}$	Continuous collector current at $T_C = 100\text{ °C}$	30	A
$I_{CP}^{(2)}$	Pulsed collector current	80	A
$V_{GE}$	Gate-emitter voltage	$V_{GE}$ (clamped)	V
$P_{TOT}$	Total dissipation at $T_C = 25\text{ °C}$	176	W
$E_{AS}$	Single pulse energy ( $T_C=25\text{ °C}$ , $L=1.6\text{ mH}$ , $I_C = 22\text{ A}$ , $V_{CC} = 50\text{ V}$ )	450	mJ
ESD	Human body model ( $R=1,5\text{ k}\Omega$ , $C=100\text{ pF}$ )	8	kV
	Machine model ( $R=0$ , $C=100\text{ pF}$ )	800	V
	Charged device model	2	kV
$T_{stg}$	Storage temperature	- 55 to 175	°C
$T_j$	Operating junction temperature		

1. Calculated according to the iterative formula:

$$I_C(T_C) = \frac{T_{j(max)} - T_C}{R_{thj-c} \times V_{CE(sat)(max)}(T_{j(max)}, I_C(T_C))}$$

2. Pulse width limited by max. junction temperature allowed

**Table 3. Thermal data**

Symbol	Parameter	Value	Unit
$R_{thj-case}$	Thermal resistance junction-case	0.85	°C/W
$R_{thj-amb}$	Thermal resistance junction-ambient	62.5	°C/W

## 2 Electrical characteristics

( $T_j = 25\text{ °C}$  unless otherwise specified)

**Table 4. Static**

Symbol	Parameter	Test conditions	Min.	Typ.	Max.	Unit
$V_{CES(\text{clamped})}$	Collector emitter clamped voltage ( $V_{GE}=0$ )	$I_C=2\text{ mA}$ , $T_j = -40\text{ °C to }150\text{ °C}$	320	345	380	V
$V_{(BR)ECS}$	Emitter collector break-down voltage ( $V_{GE}=0$ )	$I_C = 75\text{ mA}$	20	28		V
$V_{GE(\text{clamped})}$	Gate emitter clamped voltage	$I_G = \pm 2\text{ mA}$	12	14	16	V
$I_{CES}$	Collector cut-off current ( $V_{GE} = 0$ )	$V_{CE} = 15\text{ V}$ , $T_j = 150\text{ °C}$			10	$\mu\text{A}$
		$V_{CE} = 200\text{ V}$ , $T_j = 150\text{ °C}$			100	$\mu\text{A}$
$I_{GES}$	Gate-emitter leakage current ( $V_{CE} = 0$ )	$V_{GE} = \pm 10\text{ V}$	500	625	830	$\mu\text{A}$
$R_{GE}$	Gate emitter resistance		12	15	20	$\text{k}\Omega$
$R_G$	Gate resistance			1.5		$\text{k}\Omega$
$V_{GE(\text{th})}$	Gate threshold voltage	$V_{CE} = V_{GE}$ , $I_C = 1\text{ mA}$ , $T_j = -40\text{ °C}$	1.4			V
		$V_{CE} = V_{GE}$ , $I_C = 1\text{ mA}$	1.2	1.6	2.3	V
		$V_{CE} = V_{GE}$ , $I_C = 1\text{ mA}$ , $T_j = 150\text{ °C}$	0.7			V
$V_{CE(\text{sat})}$	Collector-emitter saturation voltage	$V_{GE} = 4.5\text{ V}$ , $I_C = 10\text{ A}$		1.15	1.5	V
		$V_{GE} = 4.5\text{ V}$ , $I_C = 15\text{ A}$		1.3	1.7	V

**Table 5. Dynamic**

Symbol	Parameter	Test conditions	Min.	Typ.	Max.	Unit
$C_{ies}$	Input capacitance	$V_{CE} = 25\text{ V}$ , $f = 1\text{ MHz}$ , $V_{GE} = 0$	-	700	-	pF
$C_{oes}$	Output capacitance		-	150	-	pF
$C_{res}$	Reverse transfer capacitance		-	6	-	pF

Table 6. Functional characteristics

Symbol	Parameter	Test conditions	Min.	Typ.	Max.	Unit
U.I.S.	Functional test open secondary coil	$R_G = 0$ , $T_j = 150\text{ °C}$ , $V_{CC} = 50\text{ V}$ , $V_{GE} = 5\text{ V}$ , $L = 1.6\text{ mH}$	18	-	-	A

Table 7. Switching time

Symbol	Parameter	Test conditions	Min.	Typ.	Max.	Unit	
$t_{d(on)}$ $t_r$	<b>Resistive load</b> Turn-on delay time	$V_{CC} = 14\text{ V}$ , $R_L = 1\ \Omega$ , $V_{GE} = 5\text{ V}$	-	1.1	-	$\mu\text{s}$	
	Rise time					7	$\mu\text{s}$
$t_{d(on)}$ $t_r$	<b>Resistive load</b> Turn-on delay time	$V_{CC} = 14\text{ V}$ , $R_L = 1\ \Omega$ , $V_{GE} = 5\text{ V}$ $T_j = 150\text{ °C}$	-	1	-	$\mu\text{s}$	
	Rise time					6.6	$\mu\text{s}$
$t_{d(off)}$ $t_f$ dv/dt	<b>Inductive load</b> Turn-off delay time	$V_{CC} = 300\text{ V}$ , $L = 1\text{ mH}$ $I_C = 15\text{ A}$ , $V_{GE} = 5\text{ V}$	-	26.5	-	$\mu\text{s}$	
	Fall time					5.5	$\mu\text{s}$
	Turn-off voltage slope					70	V/ $\mu\text{s}$
$t_{d(off)}$ $t_f$ dv/dt	<b>Inductive load</b> Turn-off delay time	$V_{CC} = 300\text{ V}$ , $L = 1\text{ mH}$ $I_C = 15\text{ A}$ , $V_{GE} = 5\text{ V}$ $T_j = 150\text{ °C}$	-	28	-	$\mu\text{s}$	
	Fall time					9	$\mu\text{s}$
	Turn-off voltage slope					65	V/ $\mu\text{s}$

## 2.1 Electrical characteristics (curves)

**Figure 2. Collector-emitter saturation voltage vs temperature**      **Figure 3. Self clamped inductive switch**

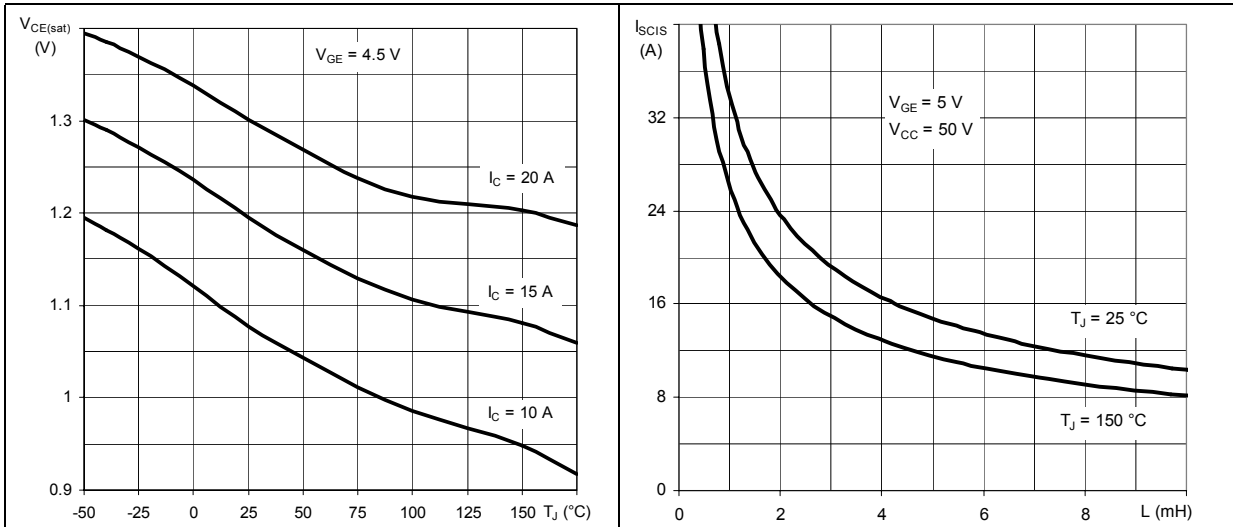

**Figure 4. Output characteristics ( $T_J = 25$  °C)**      **Figure 5. Output characteristics ( $T_J = -40$  °C)**

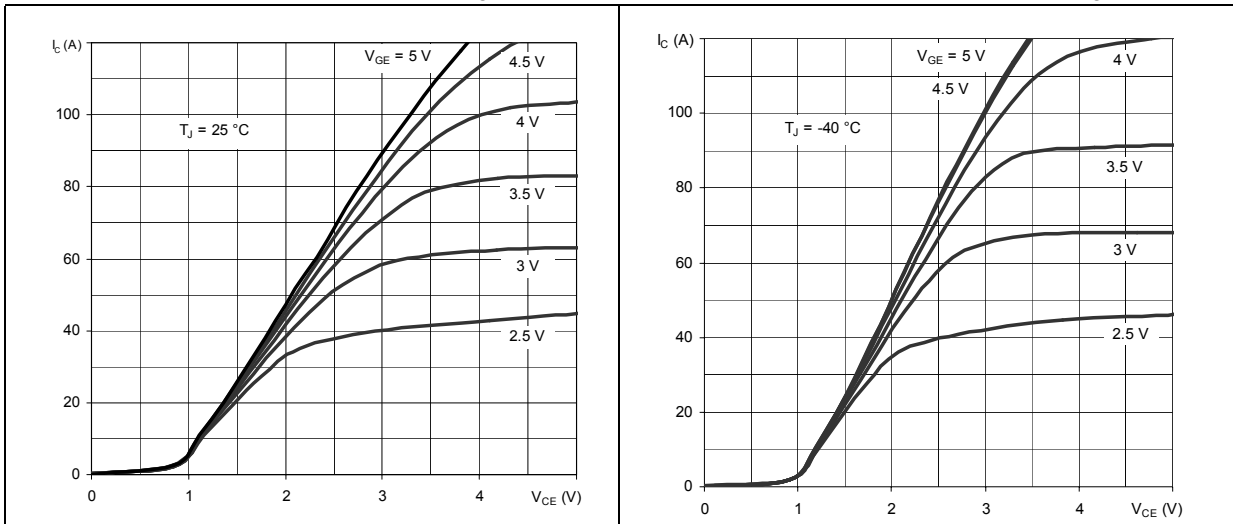

Figure 6. Output characteristics ( $T_J = 175\text{ }^\circ\text{C}$ ) Figure 7. Transfer characteristics

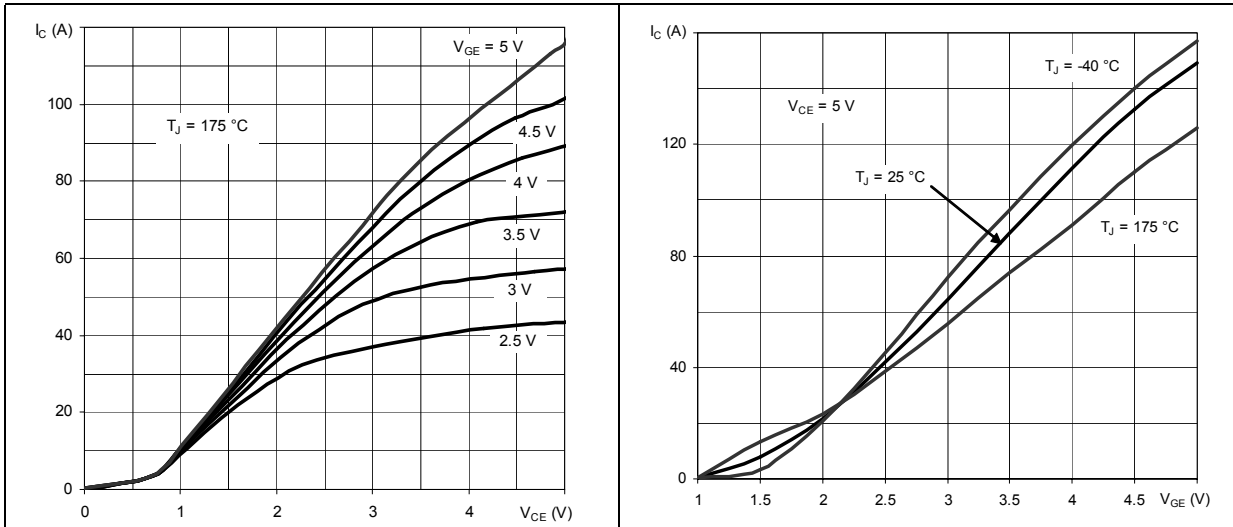

Figure 8. Collector cut-off current vs temperature

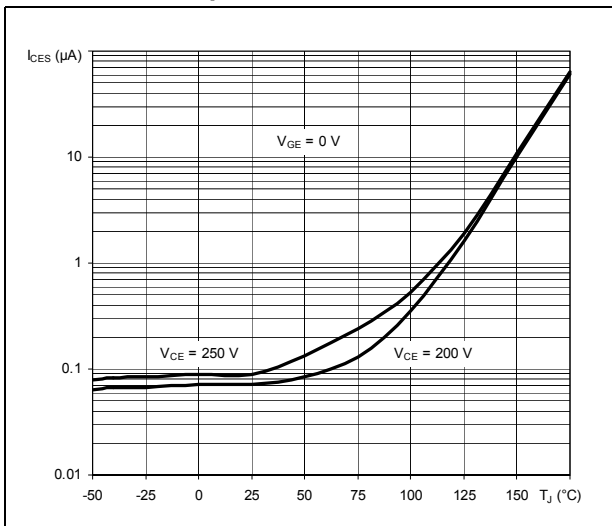

Figure 9. Normalized collector emitter voltage vs temperature

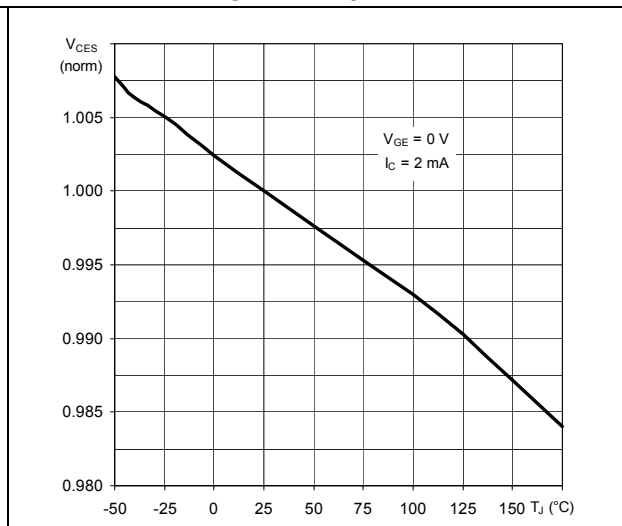
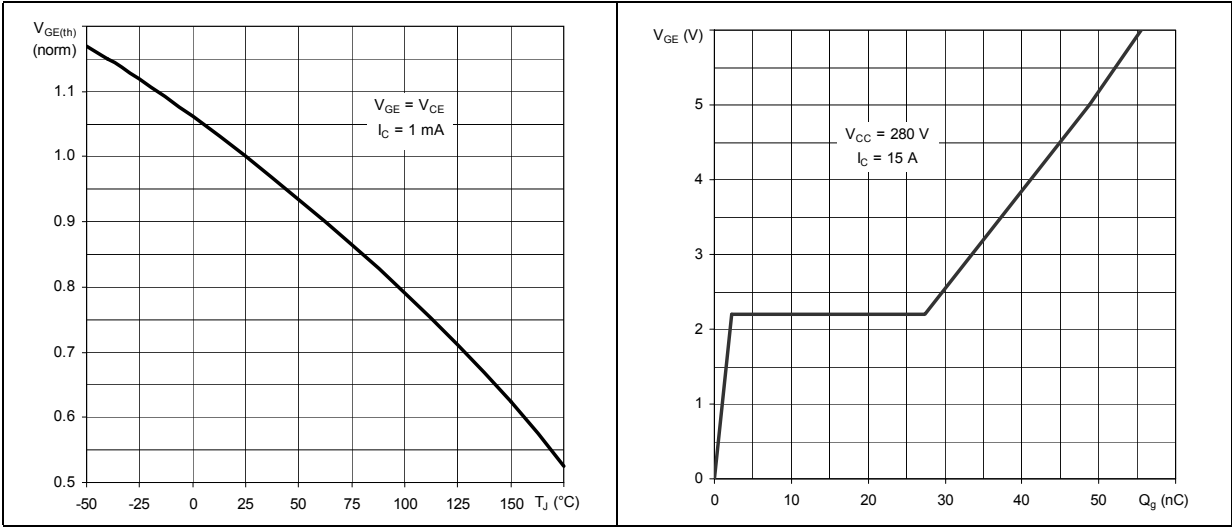

Figure 10. Normalized gate threshold voltage vs temperature      Figure 11. Gate charge







## 4 Package mechanical data

In order to meet environmental requirements, ST offers these devices in different grades of ECOPACK<sup>®</sup> packages, depending on their level of environmental compliance. ECOPACK<sup>®</sup> specifications, grade definitions and product status are available at: [www.st.com](http://www.st.com). ECOPACK is an ST trademark.

I<sup>2</sup>PAK (TO-262) mechanical data

Dim	mm			inch		
	Min	Typ	Max	Min	Typ	Max
A	4.40		4.60	0.173		0.181
A1	2.40		2.72	0.094		0.107
b	0.61		0.88	0.024		0.034
b1	1.14		1.70	0.044		0.066
c	0.49		0.70	0.019		0.027
c2	1.23		1.32	0.048		0.052
D	8.95		9.35	0.352		0.368
e	2.40		2.70	0.094		0.106
e1	4.95		5.15	0.194		0.202
E	10		10.40	0.393		0.410
L	13		14	0.511		0.551
L1	3.50		3.93	0.137		0.154
L2	1.27		1.40	0.050		0.055

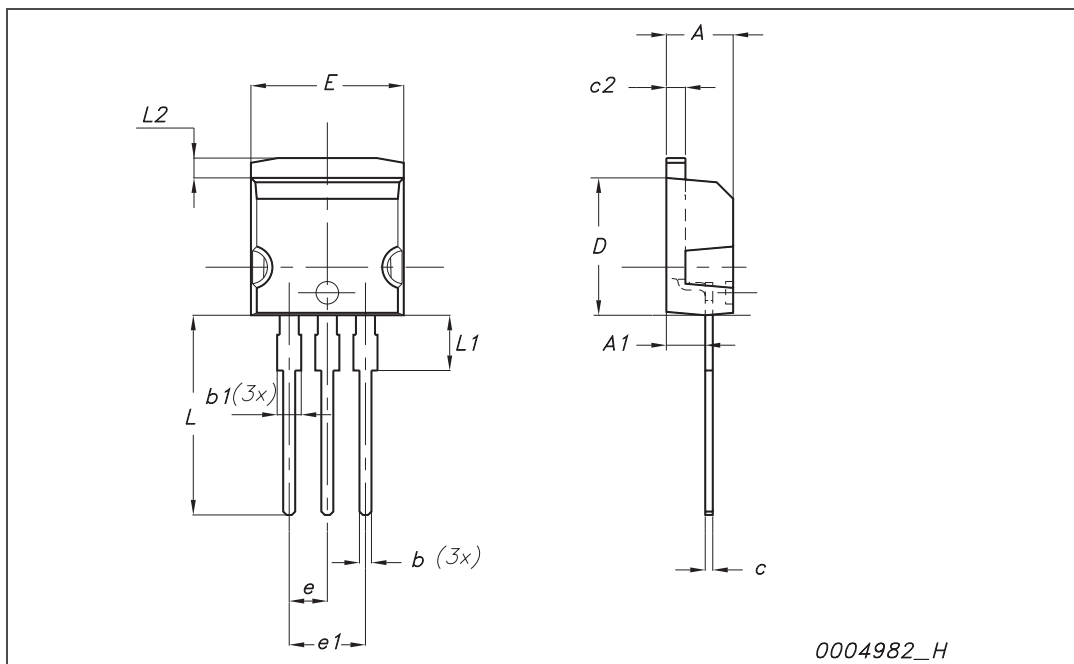

D<sup>2</sup>PAK (TO-263) mechanical data

Dim	mm			inch		
	Min	Typ	Max	Min	Typ	Max
A	4.40		4.60	0.173		0.181
A1	0.03		0.23	0.001		0.009
b	0.70		0.93	0.027		0.037
b2	1.14		1.70	0.045		0.067
c	0.45		0.60	0.017		0.024
c2	1.23		1.36	0.048		0.053
D	8.95		9.35	0.352		0.368
D1	7.50			0.295		
E	10		10.40	0.394		0.409
E1	8.50			0.334		
e		2.54			0.1	
e1	4.88		5.28	0.192		0.208
H	15		15.85	0.590		0.624
J1	2.49		2.69	0.099		0.106
L	2.29		2.79	0.090		0.110
L1	1.27		1.40	0.05		0.055
L2	1.30		1.75	0.051		0.069
R		0.4			0.016	
V2	0°		8°	0°		8°

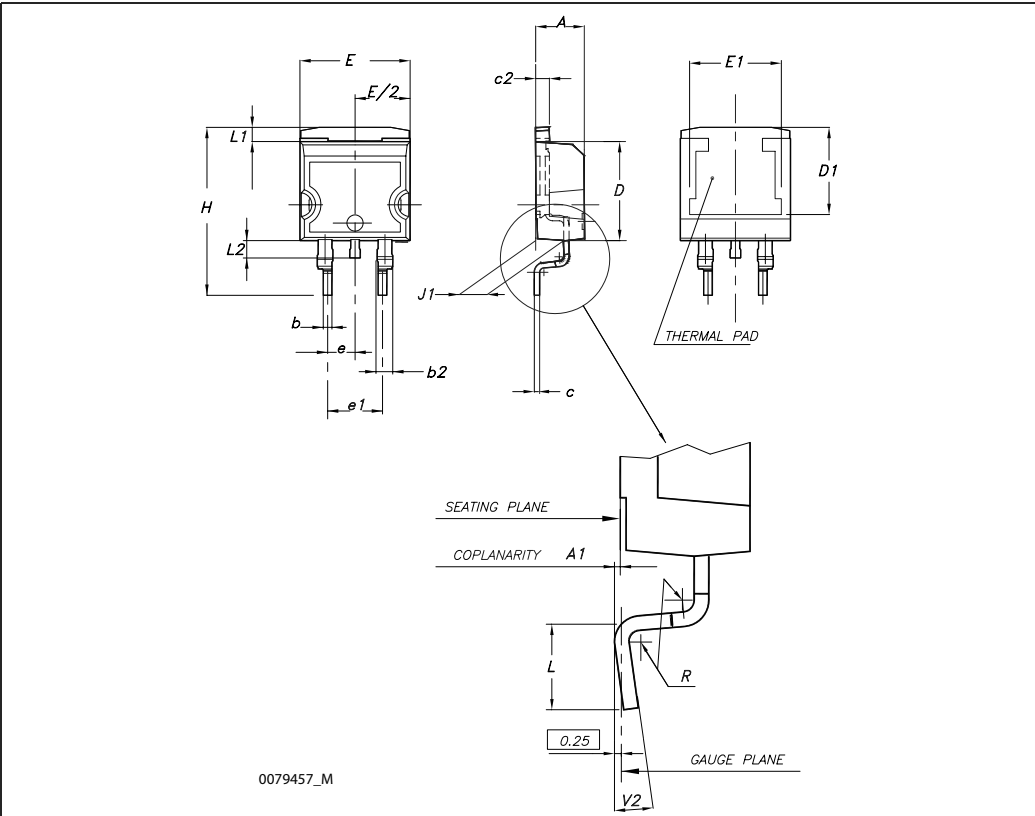

TO-220 type A mechanical data

Dim	mm		
	Min	Typ	Max
A	4.40		4.60
b	0.61		0.88
b1	1.14		1.70
c	0.48		0.70
D	15.25		15.75
D1		1.27	
E	10		10.40
e	2.40		2.70
e1	4.95		5.15
F	1.23		1.32
H1	6.20		6.60
J1	2.40		2.72
L	13		14
L1	3.50		3.93
L20		16.40	
L30		28.90	
∅P	3.75		3.85
Q	2.65		2.95

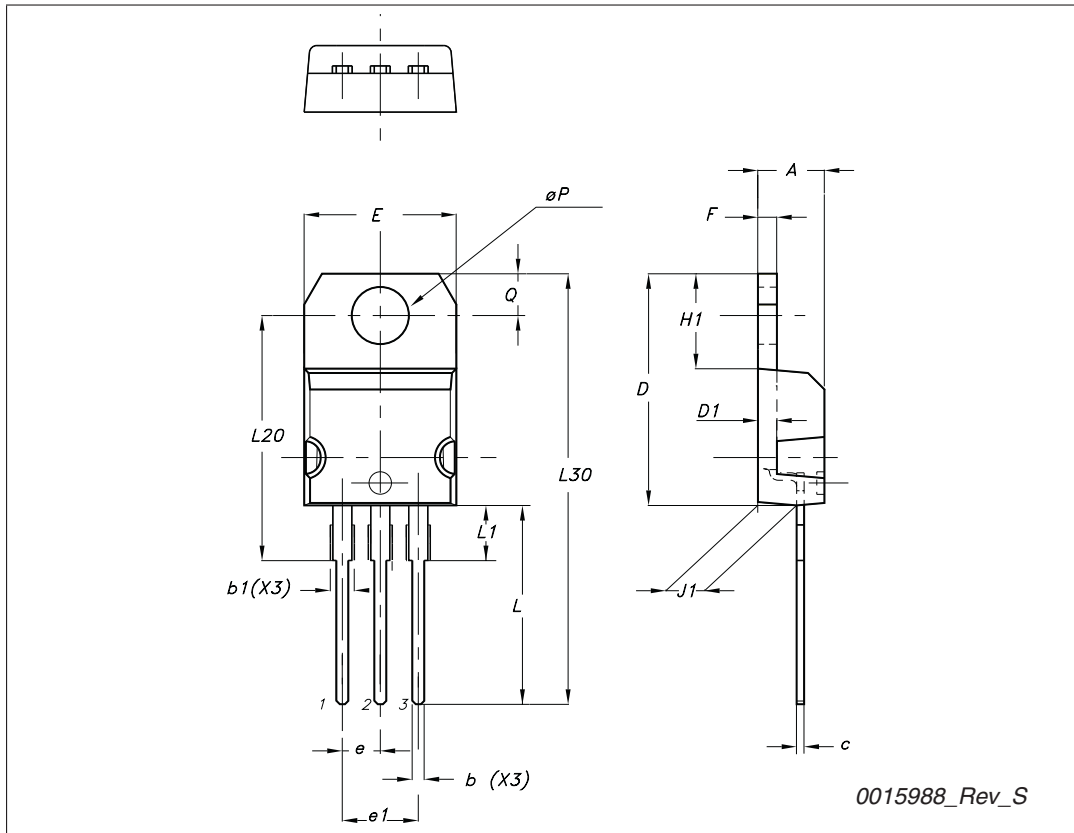

# 5 Packaging mechanical data

## D<sup>2</sup>PAK FOOTPRINT

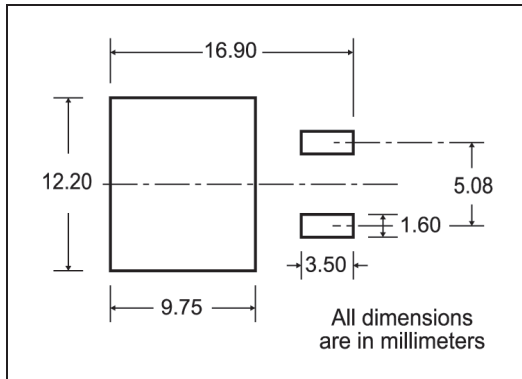

## TAPE AND REEL SHIPMENT

**TAPE MECHANICAL DATA**

DIM.	mm		inch	
	MIN.	MAX.	MIN.	MAX.
A0	10.5	10.7	0.413	0.421
B0	15.7	15.9	0.618	0.626
D	1.5	1.6	0.059	0.063
D1	1.59	1.61	0.062	0.063
E	1.65	1.85	0.065	0.073
F	11.4	11.6	0.449	0.456
K0	4.8	5.0	0.189	0.197
P0	3.9	4.1	0.153	0.161
P1	11.9	12.1	0.468	0.476
P2	1.9	2.1	0.075	0.082
R	50		1.574	
T	0.25	0.35	0.0098	0.0137
W	23.7	24.3	0.933	0.956

**REEL MECHANICAL DATA**

DIM.	mm		inch	
	MIN.	MAX.	MIN.	MAX.
A		330		12.992
B	1.5		0.059	
C	12.8	13.2	0.504	0.520
D	20.2		0.795	
G	24.4	26.4	0.960	1.039
N	100		3.937	
T		30.4		1.197

BASE QTY	BULK QTY
1000	1000

## 6 Revision history

**Table 8. Document revision history**

Date	Revision	Changes
29-Mar-2006	1	Initial release.
03-Jun-2009	2	Document status promoted from preliminary data to datasheet.
05-Nov-2009	3	Inserted <a href="#">Chapter 2.1: Electrical characteristics (curves)</a>
16-Feb-2010	4	Added new package, mechanical data: TO-220

**Please Read Carefully:**

Information in this document is provided solely in connection with ST products. STMicroelectronics NV and its subsidiaries ("ST") reserve the right to make changes, corrections, modifications or improvements, to this document, and the products and services described herein at any time, without notice.

All ST products are sold pursuant to ST's terms and conditions of sale.

Purchasers are solely responsible for the choice, selection and use of the ST products and services described herein, and ST assumes no liability whatsoever relating to the choice, selection or use of the ST products and services described herein.

No license, express or implied, by estoppel or otherwise, to any intellectual property rights is granted under this document. If any part of this document refers to any third party products or services it shall not be deemed a license grant by ST for the use of such third party products or services, or any intellectual property contained therein or considered as a warranty covering the use in any manner whatsoever of such third party products or services or any intellectual property contained therein.

**UNLESS OTHERWISE SET FORTH IN ST'S TERMS AND CONDITIONS OF SALE ST DISCLAIMS ANY EXPRESS OR IMPLIED WARRANTY WITH RESPECT TO THE USE AND/OR SALE OF ST PRODUCTS INCLUDING WITHOUT LIMITATION IMPLIED WARRANTIES OF MERCHANTABILITY, FITNESS FOR A PARTICULAR PURPOSE (AND THEIR EQUIVALENTS UNDER THE LAWS OF ANY JURISDICTION), OR INFRINGEMENT OF ANY PATENT, COPYRIGHT OR OTHER INTELLECTUAL PROPERTY RIGHT.**

**UNLESS EXPRESSLY APPROVED IN WRITING BY AN AUTHORIZED ST REPRESENTATIVE, ST PRODUCTS ARE NOT RECOMMENDED, AUTHORIZED OR WARRANTED FOR USE IN MILITARY, AIR CRAFT, SPACE, LIFE SAVING, OR LIFE SUSTAINING APPLICATIONS, NOR IN PRODUCTS OR SYSTEMS WHERE FAILURE OR MALFUNCTION MAY RESULT IN PERSONAL INJURY, DEATH, OR SEVERE PROPERTY OR ENVIRONMENTAL DAMAGE. ST PRODUCTS WHICH ARE NOT SPECIFIED AS "AUTOMOTIVE GRADE" MAY ONLY BE USED IN AUTOMOTIVE APPLICATIONS AT USER'S OWN RISK.**

Resale of ST products with provisions different from the statements and/or technical features set forth in this document shall immediately void any warranty granted by ST for the ST product or service described herein and shall not create or extend in any manner whatsoever, any liability of ST.

ST and the ST logo are trademarks or registered trademarks of ST in various countries.

Information in this document supersedes and replaces all information previously supplied.

The ST logo is a registered trademark of STMicroelectronics. All other names are the property of their respective owners.

© 2010 STMicroelectronics - All rights reserved

STMicroelectronics group of companies

Australia - Belgium - Brazil - Canada - China - Czech Republic - Finland - France - Germany - Hong Kong - India - Israel - Italy - Japan - Malaysia - Malta - Morocco - Philippines - Singapore - Spain - Sweden - Switzerland - United Kingdom - United States of America

[www.st.com](http://www.st.com)